

SPECIFICATION FOR APPROVAL

承 认 书

Description : Magnetic Transducer

Vender's Part No. : HY16G

Customer's. Part No. : _____

Serial No. : HY-1532

Version No. : 1.1

CUSTOMER'S APPROVED SIGNATURE

CUSTOMER'S APPROVED SIGNATURE		

Approved By	Checked By	Made By
QIAN WANJIN	ZHANGZHIQIANG	ZHU 2010.04.02



HYDZ[®]

兴化市华宇电子有限公司

XINGHUA HUAYU ELECTRONICS CO., LTD

地址: 江苏省兴化市陈堡工业区人民路1号

电话: 0523-83723110 传真: 0523-83723118

邮箱: China_hydz@163.com

A. SCOPE

This specification applies magnetic transducer, **HY16G**

B. SPECIFICATION

No.	Item	Unit	HY1601GA	HY1605GB	HY1612GC	Condition
1	Rated Voltage	Vo-p	3	5	12	
2	Operating Voltage	Vo-p	2~ 4	4~7	8~16	
3	Coil Resistance	Ω	16±3	42±4	80±8	
4	Oscillation Frequency	Hz	2048			Vo-p=1/2duty , square wave
5	Current Consumption	mA	MAX. 40			at Rated Voltage
6	Sound Pressure Level	dB	MIN. 85			at 10cm at Rated Voltage
7	Operating Temperature	°C	-20 ~ +70			
8	Storage Temperature	°C	-30 ~ +80			
9	Dimension	mm	Φ16 x H14			See appearance drawing
10	Weight (MAX)	gram	5.0			
11	Housing Material		PPO(Black)			
12	Leading Pin		Tin Plated Brass(Sn)			See appearance drawing
13	Environmental Protection Regulation		RoHS			

C. APPEARANCE DRAWING Tol : ± 0.5 Unit: mm

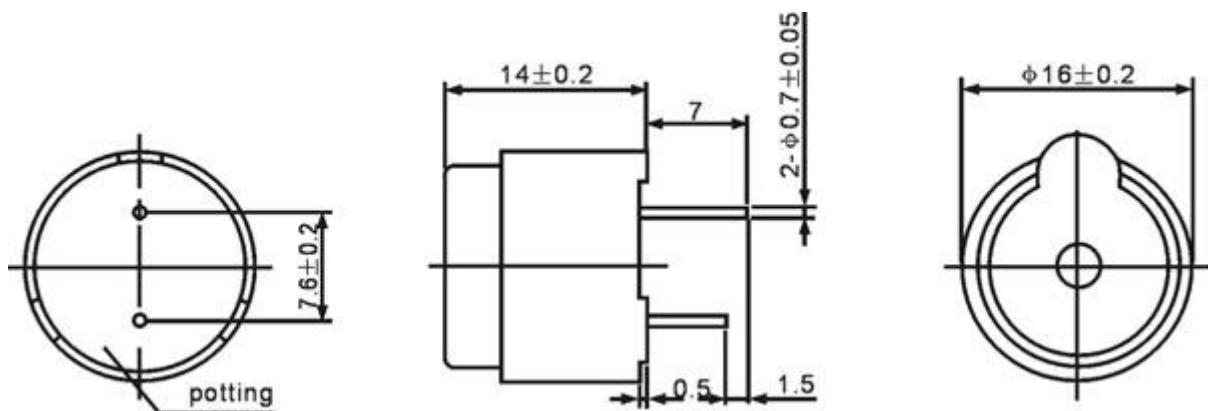

D. TESTING METHOD

Standard Measurement conditions

Temperature: $25 \pm 2^\circ\text{C}$ Humidity: 45-65%

Acoustic Characteristics:

The oscillation frequency, current consumption and sound pressure are measured by the measuring instruments shown below (Recommend Driving Circuit)

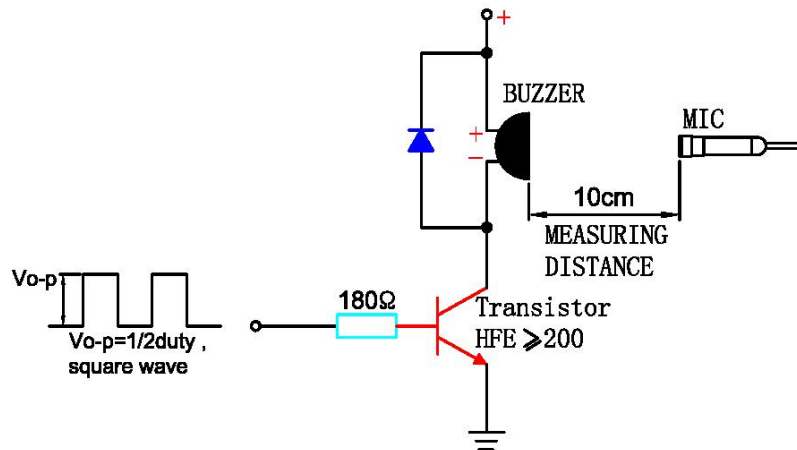

In the measuring test, buzzer is placed as follows:

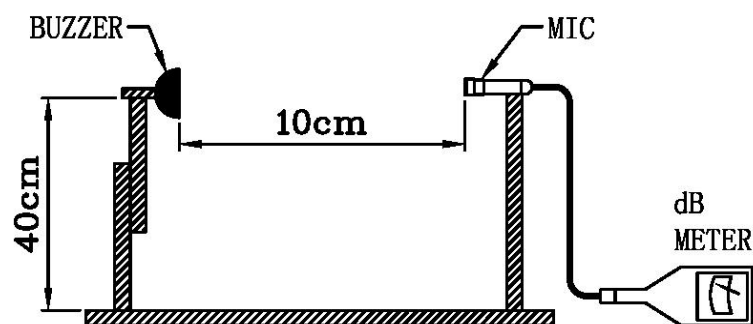

E. Typical Frequency Response Curve

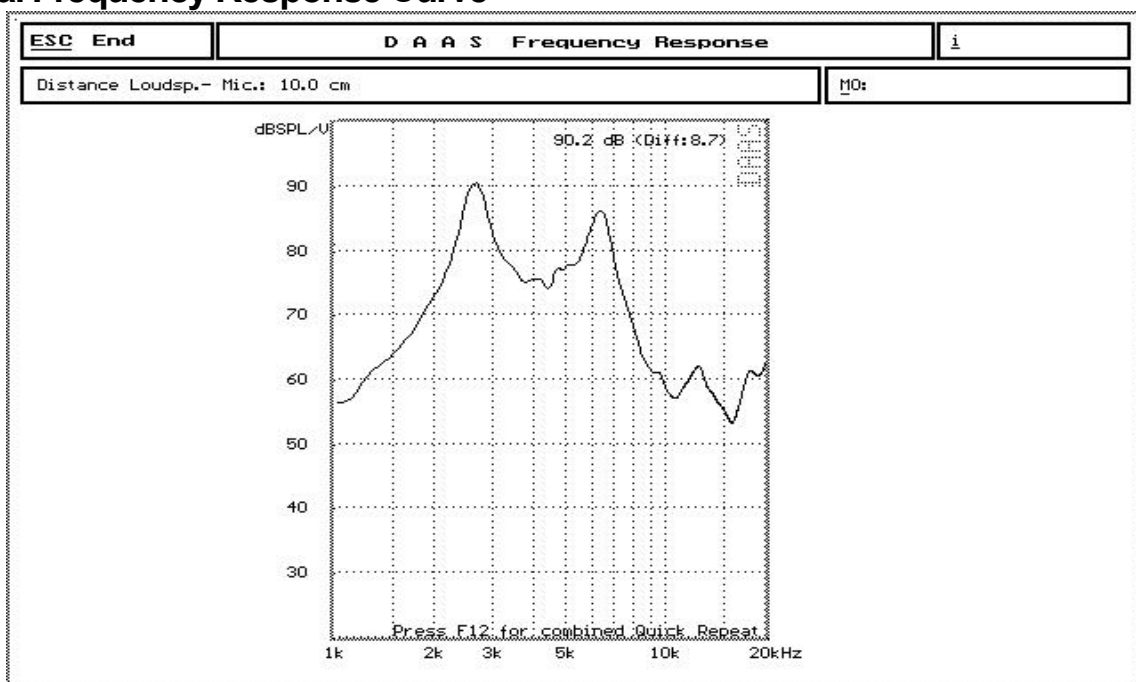

F. RELIABILITY TEST

NO.	ITEM	TEST CONDITION AND REQUIREMENT
1	High Temperature Test (Storage)	After being placed in a chamber with 70 °C for 96 hours and then being placed in normal condition for 2 hours. Allowable variation of SPL after test: 10dB.
2	Low Temperature Test (Storage)	After being Placed in a chamber with -30 °C for 96 hours and then being placed in normal condition for 2 hours. Allowable variation of SPL after test: 10dB.
3	Humidity Test	After being Placed in a chamber with 90-95% R.H. at 40 °C for 96 hours and then being placed in normal condition for 2 hours. Allowable variation of SPL after test: 10dB.
4	Temperature Cycle Test	<p>The part shall be subjected to 5 cycles. One cycle shall be consist of:</p> <p>Allowable variation of SPL after test: 10dB.</p>
5	Drop Test	Drop on a hard wood board of 4cm thick, any directions ,6 times, at the height of 75cm . Allowable variation of SPL after test: 10dB.
6	Vibration Test	After being applied vibration of amplitude of 1.5mm with 10 to 55 Hz band of vibration frequency to each of 3 perpendicular directions for 2 hours . Allowable variation of SPL after test: 10dB.
7	Solderability Test	Lead terminals are immersed in rosin for 3 seconds and then immersed in solder bath of 260°C 90% min. lead terminals shall be wet with solder (Except the edge of terminals).
8	Terminal Strength Pulling Test	The force of 9.8N(1.0kg) is applied to each terminal in axial direction for 10 seconds. No visible damage and cutting off.

TEST CONDITION.

Standard Test Condition	:	a) Temperature : +5 ~ +35°C	b) Humidity : 45-85%	c) Pressure : 860-1060mbar
一般测试条件	:	a) 温度 : +5 ~ +35°C	b) 湿度 : 45-85%	c) 气压 : 860-1060mbar
Judgment Test Condition	:	a) Temperature : +25 ± 2°C	b) Humidity : 60-70%	c) Pressure : 860-1060mbar
争议时测试条件	:	a) 温度 : +25 ± 2°C	b) 湿度 : 60-70%	c) 气压 : 860-1060mbar